

## Communications & Power Industries Magnetron



A magnetron is a high power microwave oscillator in which the potential energy of an electron cloud near the cathode is converted into RF energy in a series of cavity resonators. The VMS1197B magnetron delivers high peak and average RF power for use in medical or industrial applications.

The VMS1197B will mount directly into new and existing sockets and can be operated under various pulse and input conditions to accommodate wide ranging operating requirements. In addition to high power, the VMS1197B provides excellent frequency stability, low jitter and long life.

### FEATURES:

- Frequency 2.7 - 2.9 GHz
- Peak power output 750 kW min.
- Duty cycle 0.001
- Air cooled
- Mechanically tunable

### BENEFITS:

- Long life
- Exceptional frequency stability
- High power

### APPLICATIONS:

- Weather radars

# CPI S-Band 750 kW Magnetron VMS1197B

## Electrical Specifications

Frequency	2.7 – 2.9 GHz
Peak power output	750 kW
Average power output	750 W
Pulse voltage	29.0 – 35.0 kV
Peak anode current	75 A
Average anode current	39.4 mA
Pulse width	4.0 $\mu$ S
Duty cycle	0.001
Maximum filament voltage	11 V
Maximum filament current	22 A
Minimum warm-up time	480 S
Maximum load VSWR	1.3:1

## Mechanical and Environmental Specifications

Cooling	Forced air
Maximum body temperature	120°C
Mounting position	Any
Support	Mounting flange
Coupling	WR 284 mates with UG585A/U choke flange
Weight	75 lbs. (34.02 kg)

With a history of producing high quality products, we can help your with magnetron.

Contact us at [BMDMarketing@cpii.com](mailto:BMDMarketing@cpii.com) or call us at +1 978-922-6000.

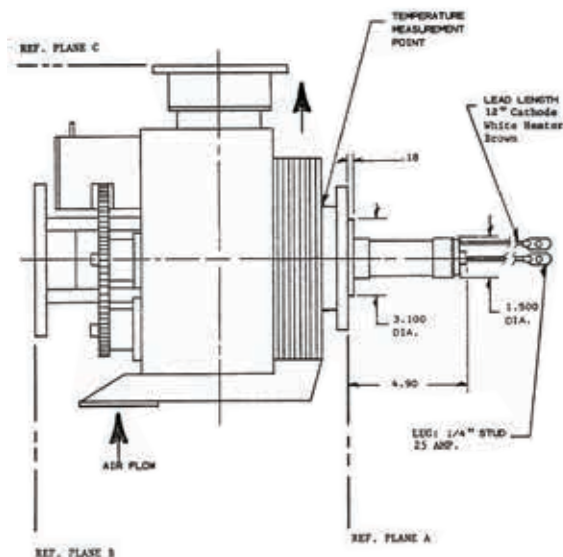
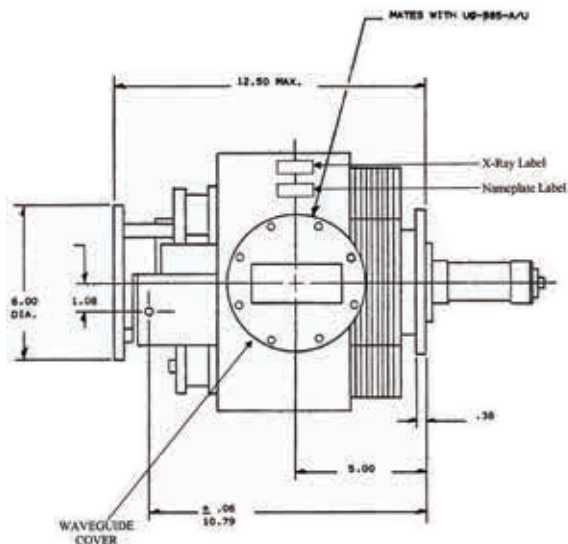

**Beverly Microwave Division**  
150 Sohier Road  
Beverly, Massachusetts  
USA 01915

tel +1 978-922-6000  
email [BMDMarketing@cpii.com](mailto:BMDMarketing@cpii.com)  
fax +1 978-922-8914  
web [www.cpii.com](http://www.cpii.com)

For more detailed information, please refer to the corresponding CPI technical description if one has been published, or contact CPI. Specifications may change without notice as a result of additional data or product refinement. Please contact CPI before using this information for system design.

©2020 Communications & Power Industries LLC. Company proprietary; use and reproduction is strictly prohibited without written authorization from CPI.